

SKIP

Poliform

# SKIP

SISTEMA LIBRERIE SKIP DESIGN STUDIO KAIROS.

SKIP, L'AREA LIVING CONTEMPORANEA ALL'INSEGNA DELLA LEGGEREZZA: UNA NUOVA DEFINIZIONE PROGETTUALE DELLA LIBRERIA ISPIRATA AL MASSIMO RIGORE GEOMETRICO PER UN SISTEMA TECNICAMENTE INNOVATIVO. LA DECLINAZIONE DEL CONCETTO DI BOISERIE ATTREZZATA IN COMPOSIZIONI DAL FORTE VALORE GRAFICO. CARATTERIZZATE DA AMPIE SUPERFICI E DA LINEE ORIZZONTALI DI MINIMO SPESSORE.

SKIP, THE CONTEMPORARY LIVING AREA IN THE NAME OF LIGHTNESS: A NEW PLANNING CONCEPT FOR THE BOOKCASE, INSPIRED TO THE MAXIMUM GEOMETRIC RIGOUR FOR A TECHNICALLY INNOVATIVE SYSTEM. A NEWLY CONCEIVED BOISERIE, ORGANISED IN COMPOSITIONS WITH A STRONG GRAPHICAL VALUE AND FEATURING WIDE SURFACES AND HORIZONTAL LINES WITH A MINIMUM THICKNESS.

Poliform

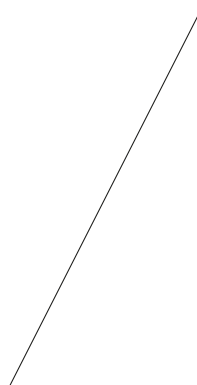

SKIP, UN SISTEMA LIBRERIA A PARETE  
DI LIBERA COMPONIBILITÀ, PER UN  
RISULTATO ESTETICO ALL'INSEGNA  
DELLA MASSIMA LEGGEREZZA.  
UN PROGETTO INNOVATIVO CHE  
COMPRENDE SCHIENALI CON MENSOLE  
DI MINIMO SPESSORE, PANCHE  
E CONTENITORI A TERRA OPPURE  
SOSPESI E PIANI SCRITTOIO.  
LE ANTE SCORREVOLI ORIZZONTALI,  
DI LIBERO INSERIMENTO, DIVENTANO  
GLI ELEMENTI CARATTERIZZANTI  
DELLE COMPOSIZIONI.  
SKIP, A WALL BOOKCASE SYSTEM WITH  
MODULAR UNITS TO BE COMBINED  
FREELY, FOR AN AESTHETIC RESULT  
IN THE NAME OF TOP LIGHTNESS.  
AN INNOVATIVE PROJECT THAT  
INCLUDES BACKRESTS WITH SHELVES  
HAVING A MINIMUM THICKNESS, BOTH  
GROUND OR HANGING BENCHES AND  
CONTAINERS, AND DESK TOPS.  
THE HORIZONTAL SLIDING DOORS,  
TO BE FREELY INSERTED, BECOME THE  
CHARACTERISING ELEMENTS OF  
THE COMPOSITIONS.

**PG.04/35 AMBIENTS**  
**PG.36/37 COMPOSITIONS**  
**PG.38/39 COMPONENTS**  
**PG.40/41 CONNECTIONS**  
**PG.42/43 FINISHINGS**



UNA ZONA LIVING CHE INTERPRETA  
UNA DIMENSIONE NATURALE, CON  
SOLUZIONI D'ARREDO  
CONTEMPORANEE. LA LIBRERIA SKIP  
SOTTOLINEA LE FORTI SUGGERZIONI  
MATERICHE DEL ROVERE SPESSART,  
IN UNA COMPOSIZIONE DI GEOMETRIA  
PRIMARIA DISEGNATA DALLE  
MENSOLE E DALLE ANTE SCORREVOLI  
ORIZZONTALI.  
A LIVING AREA INTERPRETING A  
NATURAL DIMENSION, WITH  
CONTEMPORARY FURNISHING  
SOLUTIONS. THE SKIP BOOKCASE  
HIGHLIGHTS THE STRONG MATERIAL  
SUGGESTIONS OF THE SPESSART  
OAK, IN A COMPOSITION OF PRIMARY  
GEOMETRY THAT IS DEFINED BY THE  
LACQUERED SHELVES AND BY THE  
HORIZONTAL SLIDING DOORS.



# A1,

IN QUESTA PAGINA E NELLE  
SUCCESSIVE: LIBRERIA SKIP  
CON BOISERIE E CONTENITORI ROVERE  
SPESSART MENSOLE LACCATO  
GHIACCIO, ANTE LACCATO GHIACCIO  
E GRAFITE. POLTRONCINA BB IN CUIOIO,  
DESIGN RICCARDO BLUMER E MATTEO  
BORGHI. TAVOLINO ANNA ROVERE  
SPESSART E CUIOIO, DESIGN FLAVIANO  
CAPRIOTTI. POUF PLAY RIVESTITO IN  
PELLE. SOTTO: DETTAGLIO DELLE ANTE  
SCORREVOLI IN LUCE TRA LE MENSOLE.

THIS PAGE AND THE FOLLOWING:  
SKIP BOOKCASE WITH BOISERIE  
AND SPESSART OAK CONTAINERS,  
LACQUERED SHELVES.  
BB HIDE-COVERED ARMCHAIR,  
DESIGN BY RICCARDO BLUMER  
AND MATTEO BORGHI. SPESSART OAK  
AND HIDE ANNA COFFEE TABLE,  
DESIGN BY FLAVIANO CAPRIOTTI.  
LEATHER-COVERED POUF PLAY.  
BELOW: DETAIL OF SLIDING DOORS EXPOSED  
TO LIGHT AMONG THE SHELVES.

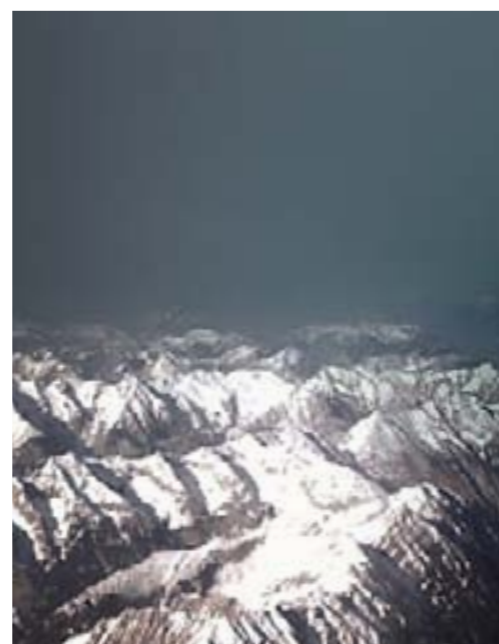

- ① contenitore sospeso / hanging unit
- ② anta scorrevole / sliding door
- ③ mensola con schienale / shelf with back panel
- ④ divisorio / dividing element

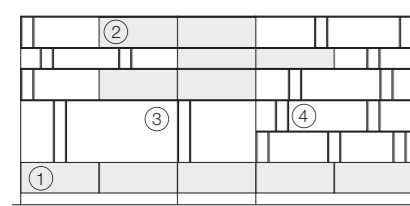

H 2166

P 538-325







# A1,

MASSIMO RIGORE ED ESSENZIALITÀ  
ISPIRANO OGNI DETTAGLIO  
DEL PROGETTO SKIP. SOTTO: LE ANTE  
DEI CONTENITORI SONO DOTATE  
DI MANIGLIA INTEGRATA.  
TOP RIGOUR AND ESSENTIALITY  
INSPIRE EVERY DETAIL OF THE SKIP  
PROJECT. BELOW: THE CONTAINERS'  
DOORS ARE EQUIPPED WITH  
BUILT-IN HANDLE.



SOTTO: DETTAGLIO DEL CONTENITORE  
CON ANTA A RIBALTA IN ROVERE  
SPESSART. I CONTENITORI SONO  
STUDIATI PER INTEGRARE AL MEGLIO  
APPARECCHIATURE AUDIO E VIDEO,  
CON UN SISTEMA INTEGRABILE  
DI RIPETITORE DI SEGNALE  
PER TELECOMANDI CHE PERMETTE  
DI UTILIZZARE DECODER E LETTORI  
ANCHE CON LE ANTE CHIUSE.

BELOW: DETAIL OF THE  
CONTAINER WITH FLIP OPENING  
DOOR IN SPESSART OAK.  
CONTAINERS ARE DESIGNED  
TO INTEGRATE AT BEST AUDIO  
AND VIDEO DEVICES, WITH A  
INTEGRABLE SYSTEM OF SIGNAL  
REPETEAR FOR TELECONTROLS  
WHICH ENABLES TO USE DVD  
PLAYERS AND DECODERS.





# A1,

IL SISTEMA SKIP PREVEDE SOLUZIONI EVOLUTE DEDICATE AI COLLEGAMENTI DELLE APPARECCHIATURE AUDIOVIDEO, PERMETTENDO UN'IDEALE ORGANIZZAZIONE DI CAVI E PRESE ELETTRICHE, TELEFONICHE E SATELLITARI.  
NELLA PAGINA A DESTRA: DETTAGLIO DELLA CANALINA ELETTRIFICATA, PERFETTAMENTE INTEGRATA NEL TOP.

THE SKIP SYSTEM INCLUDES TECHNICAL SOLUTIONS DEDICATED TO THE CONNECTIONS OF AUDIO-VIDEO DEVICES, THUS ENABLING AN IDEAL ORGANISATION OF CABLES AND SOCKETS AS WELL AS PHONE AND SATELLITE CONNECTIONS.  
ON THE RIGHT PAGE: DETAIL OF THE SLOTTED CABLE, THAT CAN BE PERFECTLY INTEGRATED IN THE TOP.



SOPRA: PARTICOLARE DEL CASSETTO, DOTATO DI SISTEMA DI APERTURA E CHIUSURA AMMORTIZZATE, CON GUIDE IN ALLUMINIO E INTERNO IN NOBILITATO BIANCO TXT.  
ABOVE: DETAIL OF THE DRAWER, EQUIPPED WITH SHOCK-ABSORBING OPENING AND CLOSING SYSTEM, WITH ALUMINIUM GUIDES AND WHITE TXT MELAMINE INTERIORS.





# A2,

CONTENITORI A TERRA IN ROVERE  
 SPESSART. SCHIENALI LACCATO  
 OPACO ARENA, MENSOLE, ANTE  
 SCORREVOLI E DIVISORI LACCATO  
 OPACO VISONE. POLTRONA E POUF  
 BUG RIVESTITI IN PELLE.  
 FREE-STANDING UNITS IN SPESSART  
 OAK. BACK PANEL MAT LACQUERED  
 ARENA, HANGING SHELVES, SLIDING  
 DOORS AND DIVIDING ELEMENTS MAT  
 LACQUERED VISONE. BUG ARMCHAIR  
 AND POUF COVERED IN LEATHER.



- ① contenitore a terra / freestanding unit
- ② anta scorrevole / sliding door
- ③ mensola con schienale / shelf with back panel
- ④ divisorio / dividing element

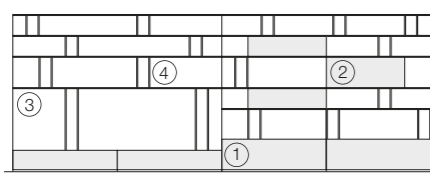

H 1806

P 538-325

4800



UNA ZONA LIVING PROIETTATA  
NELLA MODERNITÀ, TRA ORIGINALITÀ  
FORMALE E ATMOSFERE NOTTURNE,  
NEL DINTORNO DEL BIANCO,  
IL SISTEMA SKIP CREA UNA  
COMPOSIZIONE CON CONTENITORI  
A TERRA, CARATTERIZZATA DA FORTI  
CONTRASTI CROMATICI.  
A LIVING AREA PROJECTED INTO  
MODERNITY, IN-BETWEEN FORMAL  
ORIGINALITY AND NIGHT  
ATMOSPHERES, IN THE  
SURROUNDINGS OF GLOSSY WHITE,  
THE SKIP SYSTEM CREATES A  
COMPOSITION WITH GROUND  
CONTAINERS, FEATURING STRONG  
CHROMATIC CONTRASTS.



# B1,

IN QUESTA PAGINA E NELLE SUCCESSIVE:  
 LIBRERIA SKIP LACCATO OPACO BIANCO  
 CON ANTA SCORREVOLE LACCATO  
 PETROLIO. POLTRONA BIG BUG RIVESTITA  
 IN PELLE E TAVOLINO CHEESE IN ALLUMINIO  
 SPAZZOLATO LUCIDO, DESIGN PAOLA  
 NAVONE. TAVOLINO MARTÌ IN CORIAN  
 DUPONT BIANCO, DESIGN GIAMPIERO PEIA.  
 TAVOLO AIR IN CRISTALPLANT BIANCO,  
 DESIGN CARLO COLOMBO. SEDIE VENUS  
 DESIGN MARCEL WANDERS.

THIS PAGE AND THE FOLLOWING: SKIP  
 BOOKCASE GLOSSY LACQUERED WHITE  
 WITH SLIDING DOORS LACQUERED  
 PETROLIO. BIG BUG ARMCHAIR COVERED  
 WITH LEATHER AND CHEESE COFFEE TABLE,  
 IN BRILLIANT POLISHED ALUMINIUM,  
 DESIGN PAOLA NAVONE. MARTÌ COFFEE  
 TABLE IN WHITE DUPONT CORIAN, DESIGN  
 GIAMPIERO PEIA. AIR TABLE IN WHITE  
 CRISTALPLANT, DESIGN CARLO COLOMBO.  
 VENUS CHAIRS DESIGN MARCEL WANDERS.



- ① contenitore a terra / base unit
- ② anta scorrevole / sliding door
- ③ mensola con schienale / shelf with back panel
- ④ divisorio / dividing element

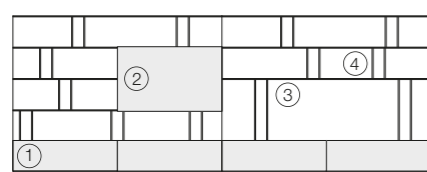

H 1806

P 538-325

4800





 **B1,**

SOTTO: L'ANTA SCORREVOLE ESTERNA ALLE MENSOLE.  
IN BASSO A DESTRA: PARTICOLARE DELLE BASI A TERRA CON ANTE DOTATE DI MANIGLIA INTEGRATA.  
BELOW: THE SLIDING DOOR, EXTERNAL TO THE SHELVES.  
BELOW ON THE RIGHT: DETAIL OF GROUND BASIS WITH DOORS EQUIPPED WITH BUILT-IN HANDLE.

UN'IDEA CONTEMPORANEA DELLA COMPONIBILITÀ, IN CUI ALLA GRIGLIA RIGOROSA DELLE LINEE FA DA CONTRAPPUNTO LA LIBERTÀ D'INSERIMENTO DELLE ANTE SCORREVOLI. IL BINARIO INTEGRATO NELLE MENSOLE È UNA SOLUZIONE CHE PERMETTE DI PREVEDERE L'INSERIMENTO DELLE ANTE IN LUCE OPPURE ESTERNE.

A CONTEMPORARY IDEA OF MODULARITY, IN WHICH THE RIGOROUS LINE GRID IS COMPENSATED BY THE FREE INSERTION OF THE SLIDING DOORS. THE RAIL BUILT-IN THE SHELVES IS A SOLUTION THAT ENABLES TO FORESEE THE INSERTION OF DOORS IN LIGHT OR EXTERNAL DOORS.

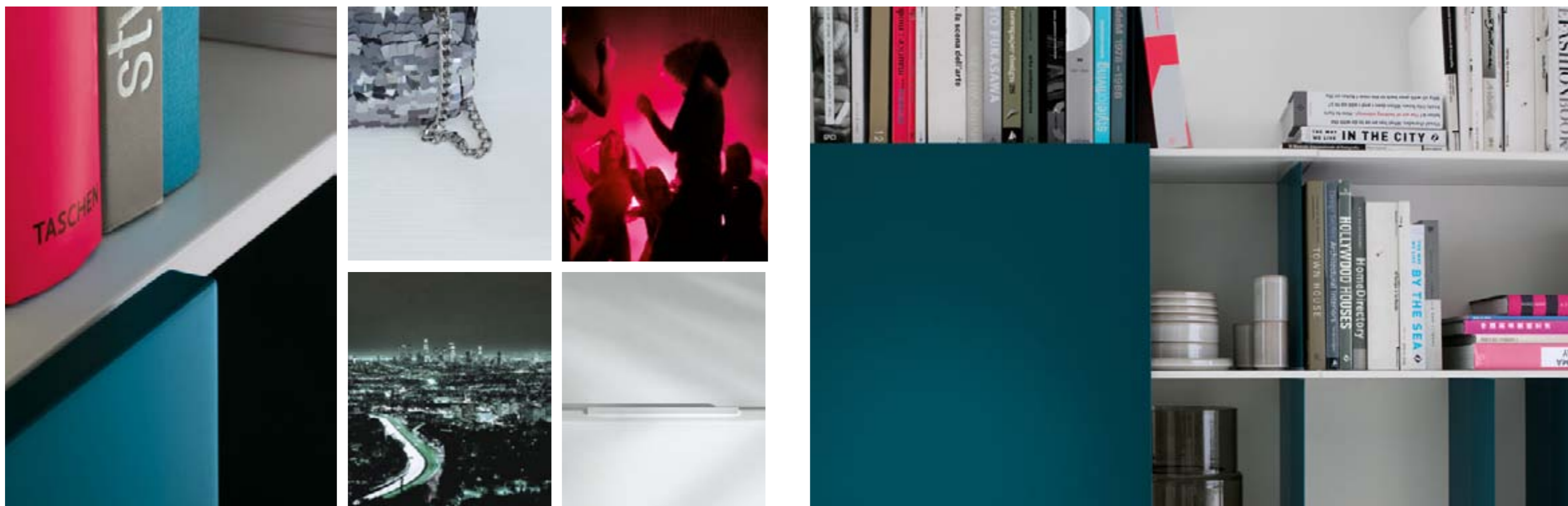



# B2,

CONTENITORI A TERRA, MENSOLA SCRITTOIO E ANTA SCORREVOLE LACCATO OPACO ZOLFO. SCHIENALI, MENSOLE, ANTE SCORREVOLI E DIVISORI LACCATO OPACO AVIO. SEDIA VENUS CON SCOCCA IN MATERIALE PLASTICO, SEDUTA IMBOTTITA E RIVESTITA IN PELLE. POUF PLAY RIVESTITO IN TESSUTO. FREESTANDING UNITS, HANGING SHELF WRITING DESK AND SLIDING DOOR MAT LACQUERED ZOLFO. BACK PANEL, HANGING SHELVES, SLIDING DOORS AND DIVIDING ELEMENTS MAT LACQUERED AVIO. VENUS CHAIR WITH BODY IN PLASTIC MATERIAL, UPHOLSTERED SEATING COVERED IN LEATHER. PLAY POUF COVERED WITH FABRIC.



- ① contenitore a terra / freestanding unit
- ② anta scorrevole / sliding door
- ③ mensola con schienale / shelf with back panel
- ④ divisorio / dividing element
- ⑤ mensolone scrittoio / hanging shelf writing desk

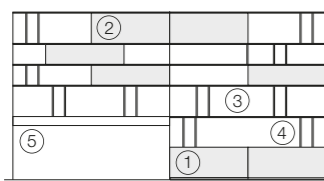

H 1926

P 538-325



ABITARE IN UN CONTESTO RICCO DI MEMORIA, AL CENTRO DI UNA CITTÀ STORICA. IL SISTEMA SKIP INTERPRETA UNA COMPOSIZIONE DI GRANDE RESPIRO FRA SPAZI LUMINOSI, STUCCHI E SUGGERZIONI DI UN APPARTAMENTO D'EPOCA. DALLA LIBRERIA AI COMPLEMENTI, LE SCELTE D'ARREDO MIRANO A RISPETTARE LO STILE ORIGINARIO, SUGGERENDO ACCOSTAMENTI DELICATI, ATTENTAMENTE DOSATI. LIVING IN A CONTEXT THAT IS FULL OF MEMORY, IN THE MIDDLE OF A HISTORICAL TOWN, THE SKIP SYSTEM INTERPRETS A PARAMOUNT COMPOSITION, IN-BETWEEN LUMINOUS SPACES, STUCCO WORKS AND THE CHARM OF A PERIOD FLAT. FROM THE BOOKCASE TO THE COMPLEMENTS, THE FURNISHING CHOICES AIM AT RESPECTING THE ORIGINAL STYLE, THUS SUGGESTING DELICATE COMBINATIONS, THAT ARE CAREFULLY DOSED.

# A C1,

IN QUESTA PAGINA E NELLE SUCCESSIVE:  
 LIBRERIA SKIP LACCATO OPACO  
 BIANCO. POLTRONA GASTON  
 RIVESTITA IN PELLE, DESIGN  
 VINCENT VAN DUYSSEN. POUF PLAY  
 RIVESTITO IN TESSUTO SFODERABILE.  
 A DESTRA: UN PUNTO DI VISTA CHE  
 SOTTOLINEA LA RIGOROSA GEOMETRIA  
 DELLA COMPOSIZIONE.  
 NEL PARTICOLARE IN BASSO: LA PANCA  
 CON ZOCCOLO IN ALLUMINIO.

THIS PAGE AND THE FOLLOWING:  
 SKIP BOOKCASE WHITE MAT  
 LACQUERED. GASTON ARMCHAIR  
 COVERED IN LEATHER, DESIGN  
 VINCENT VAN DUYSSEN. PLAY POUF  
 COVERED IN REMOVABLE FABRIC.  
 ON THE RIGHT: A POINT OF VIEW  
 HIGHLIGHTING THE RIGOROUS  
 GEOMETRY OF THE COMPOSITION.  
 MOST IN DETAIL: BENCH  
 WITH ALUMINIUM BASEBOARD.



- ① panca / bench
- ② anta scorrevole / sliding door
- ③ mensola con schienale / shelf with back panel
- ④ divisorio / dividing element

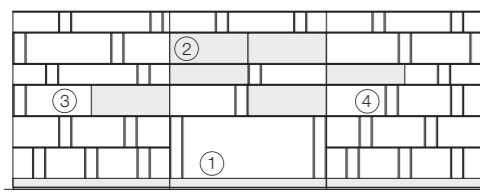

H 2046

P 538-325





# A C1,

SOTTO: IL SISTEMA PREVEDE UN'AMPIA VARIETÀ DI SOLUZIONI ESCLUSIVE, COME I VANI DOTATI DI ILLUMINAZIONE LED INTEGRATA NELLA MENSOLA.  
BELOW: THE SYSTEM INCLUDES A WIDE VARIETY OF EXCLUSIVE SOLUTIONS, SUCH AS THE COMPARTMENTS EQUIPPED WITH LED LIGHTING SYSTEM BUILT-IN THE SHELF.



UN'ESTETICA IN CUI L'ALTERNARSI DI VANI A GIORNO E ANTE CREA RELAZIONI GEOMETRICHE SEMPRE DIVERSE NELLE COMPOSIZIONI. IL SISTEMA SKIP PREVEDE TRE DIVERSE ALTEZZE PER LE ANTE SCORREVOLI: 222, 342 E 742 MM. IL PROGETTO TROVA IL PROPRIO FULCRO NELLE MENSOLE DELLO SPESSORE MINIMO DI 12 MM, IN CUI SONO PERFETTAMENTE INTEGRATI I BINARI DI SCORRIMENTO DELLE ANTE.

AN AESTHETICS IN WHICH THE ALTERNATION OF COMPARTMENTS AND DOORS CREATES QUITE DIFFERENT GEOMETRICAL RELATIONS IN THE COMPOSITIONS. THE SKIP SYSTEM FORESEES THREE DIFFERENT HEIGHTS FOR SLIDING DOORS: 222, 342 AND 742 MM. THE PROJECT FOCUSES ON THE SHELVES, WITH A MINIMUM 12 MM THICKNESS, IN WHICH THE DOORS' SLIDING RAILS ARE PERFECTLY INTEGRATED.



# A C1,

A DESTRA: UN DETTAGLIO DEI DIVISORI VERTICALI, IN ALLUMINIO LACCATO, CARATTERIZZATI DALLA PARTICOLARE SEZIONE. UN ALTRO DETTAGLIO CHE CONTRIBUISCE A DEFINIRE L'IMMAGINE DI LEGGEREZZA CHE CARATTERIZZA LE COMPOSIZIONI DEL SISTEMA SKIP.

ON THE RIGHT: A DETAIL OF VERTICAL PARTITIONS, IN LACQUERED ALUMINIUM, FEATURING A SPECIAL SECTION. ANOTHER DETAIL THAT CONTRIBUTES TO DEFINE THE LIGHTNESS CONCEPT THAT CHARACTERISES THE SKIP SYSTEM'S COMPOSITIONS.



IN ALTO: LA POLTRONA GASTON, DESIGN VINCENT VAN DUYSSEN, UNA PROPOSTA DELLA COLLEZIONE COMPLEMENTI POLIFORM: UN'ECCELLENTI VARIETÀ ESTETICA PER SOLUZIONI D'ARREDO COMPLETE, CARATTERIZZATE DALLA MASSIMA COERENZA STILISTICA.  
 ABOVE: THE GASTON ARMCHAIR, DESIGN VINCENT VAN DUYSSEN, A PROPOSAL FROM POLIFORM FURNISHING ACCESSORIES COLLECTION: AN EXCEPTIONAL AESTHETIC VARIETY FOR COMPLETE FURNISHING SOLUTIONS, FEATURING THE HIGHEST STYLISTIC CONSISTENCY.



À C2,

PANCA A TERRA ROVERE SPESSART,  
 SCHIENALI, MENSOLE, ANTE  
 SCORREVOLI E DIVISORI LACCATO  
 OPACO PIOGGIA.  
 POUF GANT RIVESTITO IN PELLE,  
 DESIGN CR&S POLIFORM.  
 TAVOLINO FLUTE LACCATO LUCIDO  
 NERO, DESIGN ROBERTO BARBIERI.  
 FLOOR BENCH IN SPESSART OAK, BACK  
 PANELS, HANGING SHELVES, SLIDING  
 DOORS AND DIVIDING ELEMENTS MAT  
 LACQUERED PIOGGIA.  
 GANT POUF COVERED IN LEATHER,  
 DESIGN CR&S POLIFORM. COFFEE  
 TABLE FLUTE GLOSSY LACQUERED  
 BLACK, DESIGN ROBERTO BARBIERI.



- ① panca / bench
- ② anta scorrevole / sliding door
- ③ mensola con schienale / shelf with back panel
- ④ divisorio / dividing element

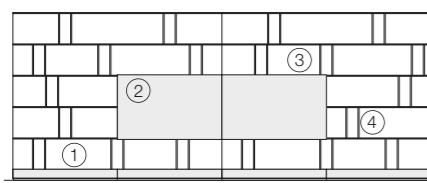

H 1926

P 365-325

# compositions,

SUGGERIMENTI COMPOSITIVI PER  
ESPLORARE AL MEGLIO LE  
POTENZIALITÀ FUNZIONALI ED  
ESTETICHE DEL SISTEMA SKIP.  
I DIVISORI VERTICALI POSSONO ESSERE  
UTILIZZATI A COPPIE OPPURE SINGOLI.  
LE COMPOSIZIONI PREVEDONO BASI A  
TERRA OPPURE SOSPESI O, IN  
ALTERNATIVA, I PIANI SCRITTOIO.  
NON SONO PREVISTI TAGLI A MISURA.

COMPOSITIONAL SUGGESTIONS TO  
EXPLORE AT BEST THE SKIP SYSTEM'S  
FUNCTIONAL AND AESTHETIC  
POTENTIALS. THE VERTICAL  
PARTITIONS CAN BE USED IN  
COUPLES OR ALONE.  
COMPOSITIONS FORESEE GROUND  
OR HANGING BASES OR, AS AN  
ALTERNATIVE, DESK-TOPS. CUSTOMISED  
CUTS ARE NOT PROVIDED.

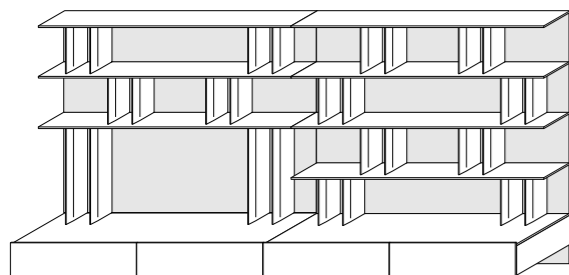

**COMPOSIZIONE 1**  
COMPOSIZIONE CON VANO TV  
E CONTENITORI SOSPESI H 366.  
COMPOSITION WITH TV ROOM  
AND HANGING CONTAINERS H 366.  
L 3600 P 538 H 1806  
W 141 3/4" D 21 3/16" H 71 1/8"

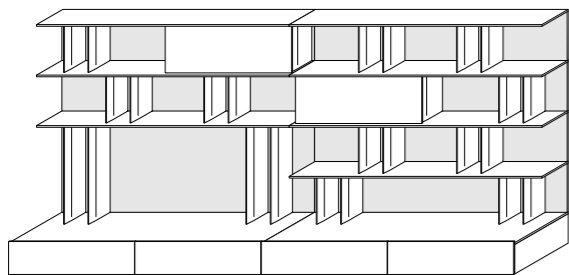

**COMPOSIZIONE 2**  
COMPOSIZIONE CON VANO TV,  
CONTENITORI A TERRA H 246  
E ANTE SCORREVOLI H 342.  
COMPOSITION WITH TV ROOM,  
GROUND CONTAINERS H 246  
AND SLIDING DOORS H 342.  
L 3600 P 538 H 1686  
W 141 3/4" D 21 3/16" H 66 3/8"

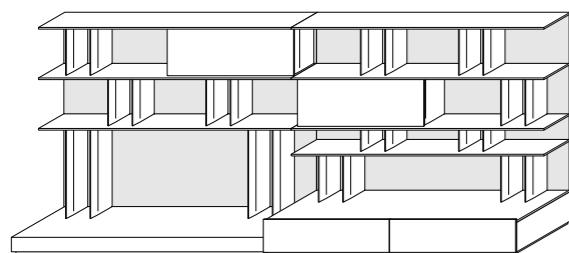

**COMPOSIZIONE 3**  
COMPOSIZIONE CON VANO TV,  
CONTENITORI A TERRA H 246,  
PANCA E ANTE SCORREVOLI H 342.  
COMPOSITION WITH TV ROOM,  
GROUND CONTAINERS H 246,  
BENCH AND SLIDING DOORS H 342.  
L 3600 P 538 H 1566  
W 141 3/4" D 21 3/16" H 61 5/8"

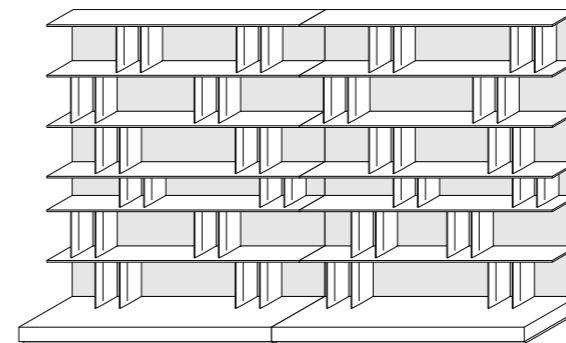

**COMPOSIZIONE 4**  
COMPOSIZIONE LIBRERIA  
CON PANCHE.  
BOOKCASE COMPOSITION  
WITH BENCHES.  
L 3600 P 538 H 2166  
W 141 3/4" D 21 3/16" H 85 1/4"

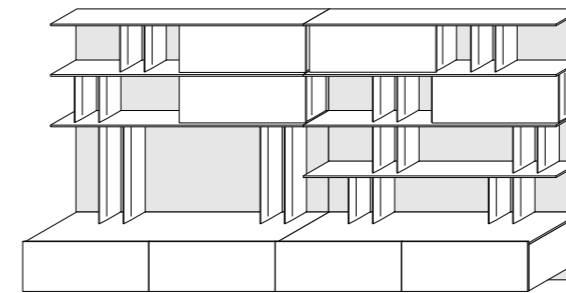

**COMPOSIZIONE 5**  
COMPOSIZIONE CON VANO TV,  
CONTENITORI SOSPESI H 486  
E ANTE SCORREVOLI H 342.  
COMPOSITION WITH TV ROOM,  
HANGING CONTAINERS H 486  
AND SLIDING DOORS H 342.  
L 3600 P 538 H 1926  
W 141 3/4" D 21 3/16" H 75 13/16"

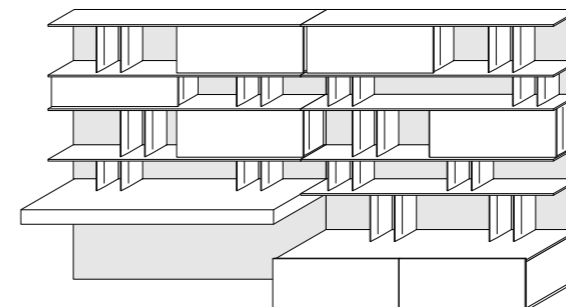

**COMPOSIZIONE 6**  
COMPOSIZIONE CON PIANO SCRITTOIO,  
CONTENITORI A TERRA H 366,  
ANTE SCORREVOLI H 222 E 342.  
COMPOSITION WITH DESKTOP,  
GROUND CONTAINERS H 366,  
SLIDING DOORS H 222 E 342.  
L 3600 P 538 H 1926  
W 141 3/4" D 21 3/16" H 75 13/16"

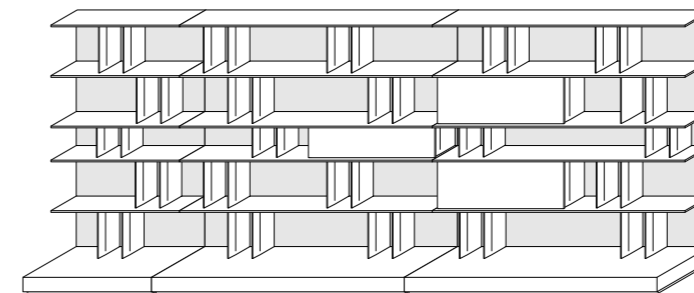

**COMPOSIZIONE 7**  
COMPOSIZIONE LIBRERIA  
CON PANCHE, ANTE SCORREVOLI  
H 222 E 342.  
BOOKCASE COMPOSITION  
WITH BENCHES, SLIDING DOORS  
H 222 E 342.  
L 4500 P 538 H 1806  
W 177 3/16" D 21 3/16" H 71 1/8"

# components,

SKIP È UN SISTEMA LIBRERIA BASATO SUL CONCETTO DI BOISERIE ATTREZZATA. UN SISTEMA DI PANNELLI A PARETE CHE VENGONO COMPLETATI CON MENSOLE, CONTENITORI E ANTE SCORREVOLI.

LA PRINCIPALE CARATTERISTICA ESTETICA DEL SISTEMA SONO LE MENSOLE DI RIDOTTISSIMA SEZIONE, DOTATE DI BINARIO PER PERMETTERE L'UTILIZZO DI, ANTE SCORREVOLI. LA GAMMA DEGLI ELEMENTI COMPOSITIVI COMPRENDE: PANCHE A TERRA, CONTENITORI A TERRA O SOSPESI CON ANTA A RIBALTA O CASSETTONE, PIANI SCRITTOIO. GLI ELEMENTI DIVISORI VERTICALI, DI LIBERO POSIZIONAMENTO, PERMETTONO DI SCANDIRE VISIVAMENTE LE COMPOSIZIONI, CREANDO VANI A GIORNO IN GRADO DI SVOLGERE MOLTEPLICI FUNZIONI.

SKIP IS A BOOKCASE SYSTEM BASED ON THE CONCEPT OF EQUIPPED WALL PANNELLING, WHICH CAN BE COMPLETED WITH SHELVES, UNITS AND SLIDING DOORS.

THE PRINCIPAL AESTHETICAL CHARACTERISTIC OF THE SYSTEM IS THE MINIMAL THICKNESS OF THE SHELVES, ENDOWED WITH THE RAIL THAT ALLOWS THE INTEGRATION OF THE SLIDING DOORS. THE RANGE OF THE MODULAR ELEMENTS INCLUDES: FLOOR BENCHES, FREESTANDING OR HANGING UNITS WITH FLAP DOORS OR CHEST OF DRAWERS, HANGING SHELF WRITING DESKS. THE VERTICAL DIVIDING ELEMENTS, THAT CAN BE FREELY POSITIONED, ALLOW MODIFYING THE COMPOSITIONS, CREATING OPEN UNITS THAT ARE ABLE TO ASSUME VARIOUS FUNCTIONS.

## panca p 365 - 538 / bench d 14 3/8" - 21 3/16"



## contenitore a terra p 538 / freestanding unit d 21 3/16"

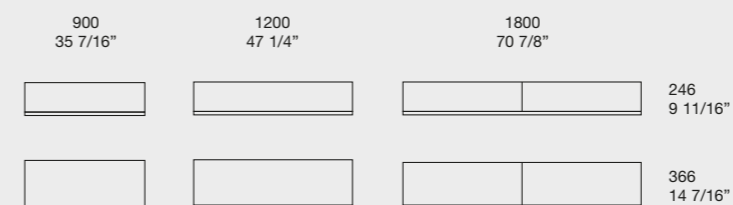

anta ribalta o cassetto  
flip opening door or drawer

## mensole scrittoio p 538 / hanging shelf writing desk d 21 3/16"

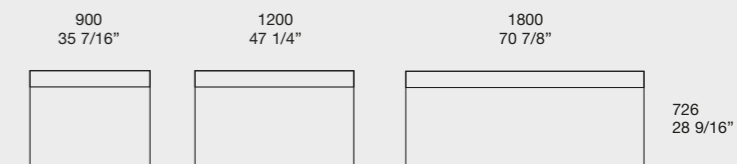

## contenitore sospeso p 485 / hanging unit d 19 1/8"

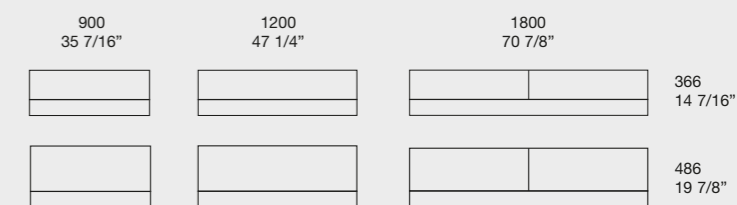

anta ribalta o cassetto  
flip opening door or drawer

## mensola con schienale p 325 / shelf with back panel d 12 13/16"

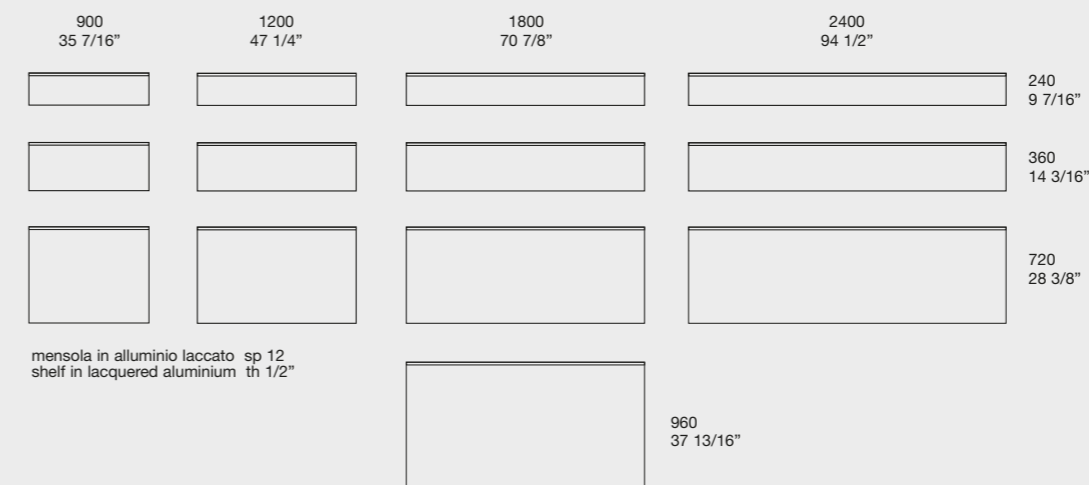

mensola in alluminio laccato sp 12  
shelf in lacquered aluminium th 1/2"

## anta scorrevole sp 12 / sliding door th 1/2"

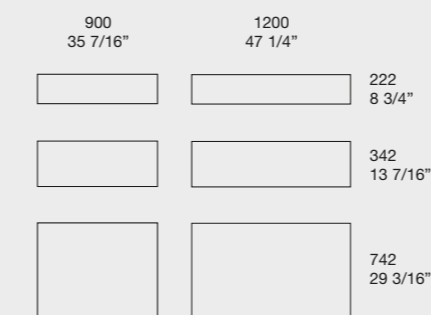

## divisorio per libreria p 261 dividing element for bookcase d 10 1/4"

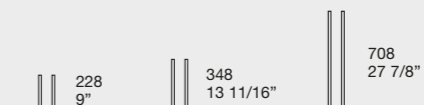

in alluminio laccato sp 3-16 - singolo o doppio  
in lacquered aluminium th 1/8" - 5/8" - single or double

# connections,

## COMPONENTI / COMPONENTS



1 canalina passacavi / slotted cable gland



2 canalina elettrificata passacavi / electrified cable gland



3 ripetitore di segnale IR / signal repeater IR

- tappo passacavi / plug cable gland
- ⚡ alimentazione / power
- ⊙ antenna / antenna
- ↔ telefono / telephone

## PANCA / BENCH

NELLE COMPOSIZIONI CON PANCA, IL CABLAGGIO DELLE APPARECCHIATURE TV, LETTORI DVD E DECODER IN APPOGGIO È POSSIBILE TRAMITE IL TAPPO PASSACAVI INTEGRATO NELLO SCHIENALE. IN COMPOSITIONS WITH BENCH, THE WIRING OF THE TV EQUIPMENT, THE DVD PLAYERS AND DECODERS CAN BE CARRIED OUT THROUGH THE PLUG CABLE BUILT IN THE BACKREST.

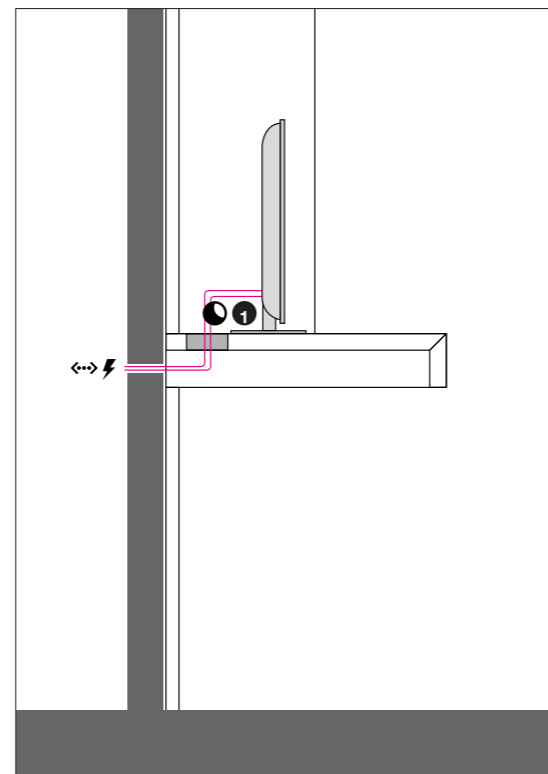
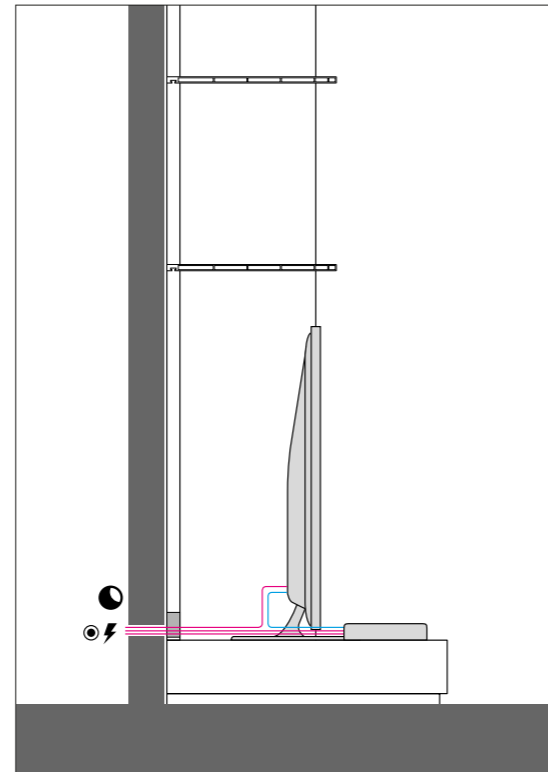

## CONTENITORE A TERRA O SOSPESO / GROUND OR HANGING CONTAINER

SONO PREVISTE DUE SOLUZIONI. A SINISTRA, TOP CON CANALINA O TAPPO PASSACAVI E SCHIENALE CONTENITORE CON TAPPO PASSACAVI. A DESTRA, TOP CON CANALINA ELETTRIFICATA PASSACAVI E SCHIENALE CONTENITORE CON TAPPO PASSACAVI. LA CANALINA ELETTRIFICATA, DOTATA DI PROFILO ANTIPOLVERE, ASSICURA UNA MAGGIORE SEMPLICITÀ NEI CABLAGGI E PERMETTE DI RIDURRE AL MINIMO IL NUMERO DI COLLEGAMENTI ELETTRICI NECESSARI. TWO SOLUTIONS ARE FORESEEN. ON THE LEFT, TOP WITH PLUG CABLE OR SLOTTED CABLE AND CONTAINER BACKREST WITH PLUG CABLE. ON THE RIGHT, TOP WITH SLOTTED CABLE AND CONTAINER BACKREST WITH PLUG CABLE. THE SLOTTED CABLE, EQUIPPED WITH ANTIDUST PROFILE, ENSURES SIMPLER WIRING AND REDUCES THE NUMBER OF ELECTRIC CONNECTIONS TO THE LEAST. TWO SOLUTIONS ARE AVAILABLE. ON THE LEFT, TOP WITH PLUG CABLE OR SLOTTED CABLE AND CONTAINER BACKREST WITH PLUG CABLE.

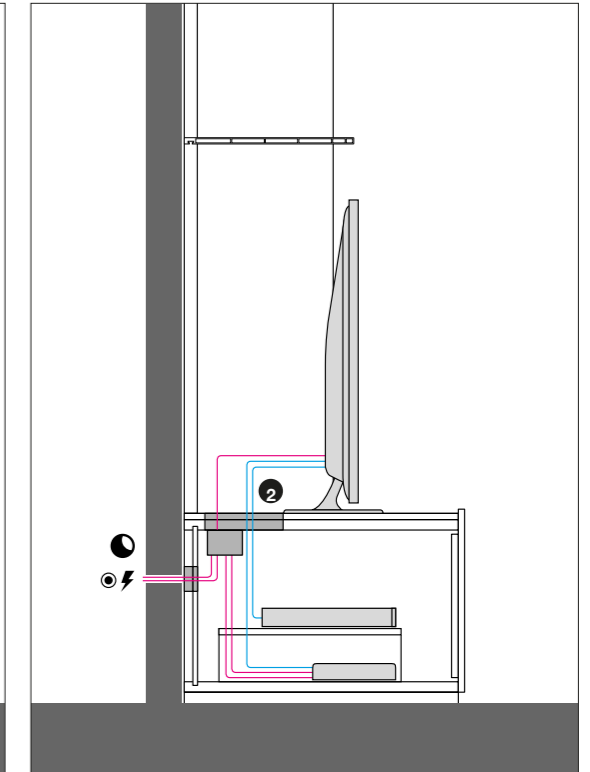
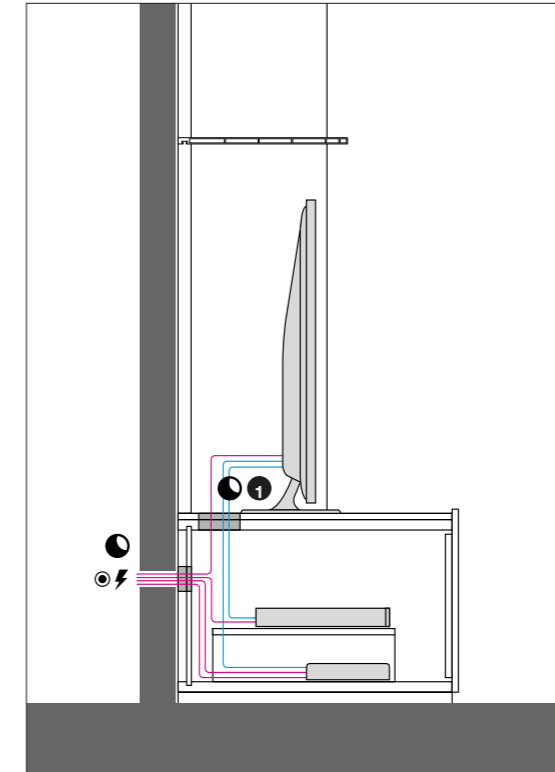

## RIPETITORE DI SEGNALE PER TELECOMANDO / SIGNAL REPEATER FOR TELECONTROL

IL RIPETITORE DI SEGNALE A INFRAROSSI CONSENTE DI UTILIZZARE I TELECOMANDI ANCHE QUANDO LE APPARECCHIATURE SONO COLLOCATE ALL'INTERNO DEI CONTENITORI. IL SISTEMA PREVEDE UN RICEVITORE DA POSIZIONARE SOPRA IL TOP, UNA CENTRALINA INTERNA E UNA BARRA TRASMETTITORE, GIÀ INTEGRATA NEL CONTENITORE. IL CABLAGGIO DELLE APPARECCHIATURE PUÒ ESSERE EFFETTUATO CON LE DUE SOLUZIONI DESCRITTE SOPRA. THE INFRARED SIGNAL REPEATER ENABLES TO USE TELECONTROLS EVEN WHEN THE DEVICES ARE PLACED INSIDE THE CONTAINERS. THE SYSTEM INCLUDES A RECEIVER TO BE PLACED ABOVE THE TOP, AN INTERNAL JUNCTION BOX AND A TRANSMITTER BAR, ALREADY BUILT IN THE CONTAINER. THE DEVICE WIRING CAN BE PERFORMED WITH THE TWO ABOVE-MENTIONED SOLUTIONS.

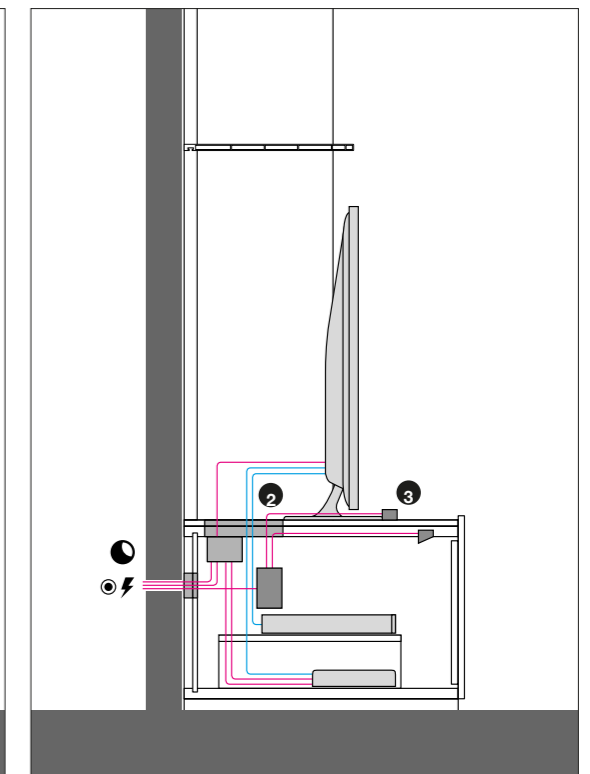
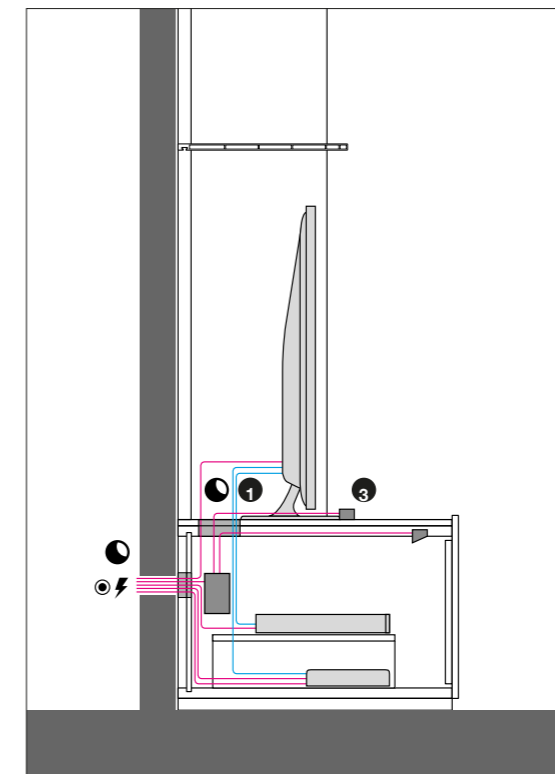

# finishings,

LE SUGGERZIONI MATERICHE DEL ROVERE SPESSART, IN ABBINAMENTO CON 28 COLORI LACCATI, DISPONIBILI NELLA FINITURA OPACA. UN'AMPIA GAMMA DI POSSIBILITÀ PER OFFRIRE LA PIÙ AMPIA LIBERTÀ DI PERSONALIZZAZIONE ESTETICA. THE MATERIAL CHARM OF SPESSART OAK CAN BE MATCHED WITH 28 LACQUERED SHADES, AVAILABLE IN THE MAT FINISH. A WIDE RANGE OF OPTIONS TO OFFER THE WIDEST FREEDOM OF AESTHETIC CUSTOMISATION.



01 BIANCO	42 PANNA	35 CANAPA	26 CORDA
60 GHIACCIO	09 PIOGGIA	78 FERRO	04 GRAFITE
64 ARENA	46 TORTORA	48 VISONE	49 MOKA
61 QUARZO	62 CRETA	63 FANGO	03 NERO
71 ZUCCA	72 CILIEGIA	39 SIENA	14 MELANZANA
65 ZOLFO	50 PRATO	66 ALLORO	67 MUSCHIO
68 AVIO	18 BLU POLVERE	69 PETROLIO	70 PRUSSIA

ART DIRECTION: PAOLO MOJOLI

FOTO:  
GIONATA XERRA

STYLING:  
RAVAIOLI SILENZI STUDIO

1° EDIZIONE LUGLIO 2010  
COD. 51/R1/2010

THANKS TO:

ARTEXA  
CALLIGARIS  
COTTO D'ESTE  
DE VECCHI  
DIMENSIONE DISEGNO  
INDUSTREAL  
L'ARTE NEL POZZO  
LEUCOS  
LUMESS  
NAHOOR  
SONY  
VIABIZZUNO  
VISTOSI



associato a  
**ASSARREDO**  
FEDERLEGNO-ARREDO

HEADQUARTERS:  
**POLIFORM SPA**  
VIA MONTESANTO 28  
CASELLA POSTALE N. 1  
22044 INVERIGO (CO) ITALY  
TEL +39/0316951  
FAX +39/031699444  
INFO.POLIFORM@POLIFORM.IT  
WWW.POLIFORM.IT

KITCHEN DIVISION:  
**VARENNA CUCINE**  
VIA DEGLI ARTIGIANI 51  
CASELLA POSTALE N. 55  
22040 LURAGO D'ERBA (CO)  
TEL +39/031695401  
FAX +39/031695444  
INFO.VARENNA@POLIFORM.IT  
WWW.POLIFORM.IT

CONTRACT DIVISION:  
**POLIFORM CONTRACT**  
VIA DANTE ALIGHIERI 48  
CASELLA POSTALE N. 55  
22040 LURAGO D'ERBA (CO)  
TEL +39/031695601  
FAX +39/031695354  
INFO.CONTRACT@POLIFORM.IT  
WWW.POLIFORM.IT

POLIFORM SI RISERVA IL DIRITTO DI APPORTARE, SENZA PREAVVISO, OGNI MODIFICA MIRATA AL MIGLIORAMENTO FUNZIONALE E QUALITATIVO DEI PROPRI PRODOTTI. TESTI E DISEGNI PRESENTI IN QUESTO STAMPATO HANNO SCOPO DIVULGATIVO: PER OGNI ASPETTO TECNICO E DIMENSIONALE FARE RIFERIMENTO AI LISTINI AZIENDALI E RELATIVI AGGIORNAMENTI. I CAMPIONI DI COLORI E MATERIALI HANNO VALORE INDICATIVO. POLIFORM RESERVES THE RIGHTS AT ALL TIME TO APPLY MODIFICATIONS FOR THE FUNCTIONAL OR QUALITATIVE IMPROVEMENT OF ITS PRODUCTS. TEXTS AND DRAWINGS PRESENT IN THIS BROCHURE HAVE A DIVULGATIVE PURPOSE: FOR EVERY TECHNICAL AND DIMENSIONAL ASPECT PLEASE REFER TO THE COMPANY'S PRICE LISTS AND THEIR RELATIVE UPDATINGS. THE COLOUR AND MATERIAL SAMPLES HAVE AN INDICATIVE VALUE.